

Direct Determination of Peracetic Acid, Hydrogen Peroxide, and Acetic Acid in Disinfectant Solutions by Far-Ultraviolet Absorption Spectroscopy

Noboru Higashi,[†] Hiroshi Yokota,[†] Satoru Hiraki,[†] and Yukihiro Ozaki^{*,‡}

Kurabo Industries Ltd., 14-5 Shimokida-cho, Neyagawa 572-0823, Japan, and Department of Chemistry and Research Center for Near Infrared Spectroscopy, School of Science and Technology, Kwansai Gakuin University, 2-1 Gakuen, Sanda 669-1337, Japan

In this paper we propose a rapid and highly selective far-ultraviolet (FUV) spectroscopic method for the simultaneous determination of peracetic acid (PAA), hydrogen peroxide, and acetic acid (AA). For this purpose we developed a novel FUV spectrometer that enables us to measure the spectra down to 180 nm. Direct determination of PAA, H₂O₂, and AA, the three main species in disinfectant solutions, was carried out by using their absorption bands in the 180–220-nm region. The proposed method does not require any reagents or catalysts, a calibration standard, and a complicated procedure for the analysis. The only preparation procedure requested is a dilution of H₂O₂ with pure water to a concentration range lower than 0.2 wt % in the sample solutions. Usually, the required concentration range can be obtained by the 10 times volume dilution of the actual disinfectant solutions. As the measured sample does not leave any impurity for the disinfection, it can be reused completely by using a circulation system. The detection limit for PAA of the new FUV spectrometer was evaluated to be 0.002 wt %, and the dynamic ranges of the measured concentrations were from 0 to 0.05 wt %, from 0 to 0.2 wt %, and from 0 to 0.2 wt % for PAA, H₂O₂, and AA, respectively. The response time for the simultaneous determination of the three species is 30 s, and the analysis is applicable even to the flowing samples. This method may become a novel approach for the continuous monitoring of PAA in disinfectant solutions on the process of sterilization.

The use of peracetic acid (PAA) for sterilization has received increasing attention as concerns about environmental spread of infectious agents have deepened and needs for so-called cold sterilization have increased. PAA displays a wide spectrum of attack against microbes.^{1–4} In addition, PAA offers the advantages

of being sporicidal at low temperature,⁵ even lower than room temperature, and of leaving only nontoxic residues.⁶ For the sake of these advantages of PAA disinfectant it has been widely used in the food industry and the health care industry as effective sterilization.^{7,8} PAA is one of the most ideal disinfectants on the process of sterile packing systems, so-called clean-in-place (CIP), for pet bottle beverages because of its rapid sporicidal effect and low-temperature sterilization.⁸

In these fabrications bottles are handled automatically from cleaned up washing and disinfecting space to cleaned up packing space immediately. On the typical process of these CIP the condensed PAA solution is diluted with pure water down to a concentration range of 0.15–0.20 wt % and heated to a temperature range of 40–50 °C. Then, it is sprayed into each bottle for only ~15 s. As the diluted disinfectant solution works to sterilize these pet bottles, the concentration of PAA decreases gradually in the solution. In the practical process of the sterilization the condensed disinfectant solution is added to the used disinfectant solution several times to prolong the life of the solution in the circulation system, and finally the waste solution is changed completely to a new solution. To ensure the effect of the disinfection the concentration of PAA has to be monitored and controlled continuously. Hence, the accurate determination of PAA is required to monitor PAA levels in the disinfectant solutions and to adjust the concentration through the addition of concentrated PAA solution. However, so far there has been no applicable method that achieves a rapid, continuous, selective, and sensitive measurement for the on-line monitoring of a PAA disinfectant solution.

A PAA solution is prepared from acetic acid (AA) and hydrogen peroxide in the presence of an acidic catalyst, typically H₂SO₄.⁹ The equilibrium state is shown in the following equation.

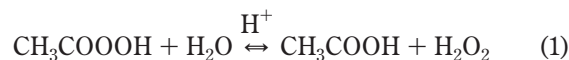

Thus, industrial PAA solutions always contain significant amounts

* Corresponding author: (e-mail) ozaki@ksc.kwansei.ac.jp.

[†] Kurabo Industries Ltd.

[‡] Kwansai Gakuin University.

- (1) Taylor, J. H.; Rogers, S. J.; Holah, J. T. *J. Appl. Microbiol.* **1999**, *87*, 718–725.
- (2) Baldry, M. G. C. *J. Appl. Bacteriol.* **1983**, *54*, 417–423.
- (3) Block, S. S. Peroxygen Compounds. In *Disinfection, Sterilization and Preservation*; Lea and Febiger: Philadelphia, PA, 1991; pp 167–181.
- (4) Lynam, P. A.; Babb, J. R.; Fraise, A. P. *J. Hosp. Infect.* **1995**, *30*, 237–240.

- (5) Jones, L. A. Jr.; Hoffman, R. K.; Phillips, C. R. *Appl. Microbiol.* **1967**, *15*, 357–362.
- (6) Swern, D. *Organic Peroxides*; Wiley-Interscience: New York, 1970; p 360.
- (7) Philip, M. S. *Polymers, Laminations & Coatings Conference; TAPPI Proc.* **1990**, *1*, 293–300.
- (8) Nicolas, R.; Nishitani, N. *Beverage Jpn.* **1996**, *169*, 62–67.

of H_2O_2 . The analysis method for PAA requires high selectivity and less cross-reaction with H_2O_2 and AA in their coexistence.

Various methods have been reported for the determination of PAA. The most widely used methods for analyzing solutions containing PAA and H_2O_2 are a method by D'Ans and Frey¹⁰ and its modification by Greenspan and Mckellar.¹¹ In their methods, H_2O_2 in a solution containing PAA and H_2O_2 is first titrated with permanganate or ceric sulfate, and the residual PAA is then determined by adding potassium iodide to the solution and titrating liberated iodine with thiosulfate. Needless to say, the two-step titration method is not suitable for the continuous monitoring of PAA because it is very time-consuming. As the alternative techniques of the titration methods for the determination of PAA, electrochemical measurements,^{12–15} chromatographic methods,^{16–20} and spectroscopic methods^{21–25} have been reported. Conductivity measurements¹² are rapid and convenient, but their common disadvantage is their low selectivity. Simultaneous determination techniques for PAA and H_2O_2 using HPLC^{18–20} or electroanalysis methods^{14,15} have successfully been demonstrated; however, they still need more than 5 min for the determination.

Spectroscopic methods have often been employed for the direct determination of a few species in aqueous solutions. Near-infrared (NIR) spectroscopy has recently been a matter of keen interest as a practical technique for a variety of water and aqueous solution analyses.^{26–30} NIR spectroscopy is useful also for the process analyses of aqueous solution systems.³⁰ However, the sensitivity of NIR spectroscopy is, in general, not very high. In the literature, several ultraviolet and visible spectroscopic methods for the photometric determination of peroxycarboxylic acids have been

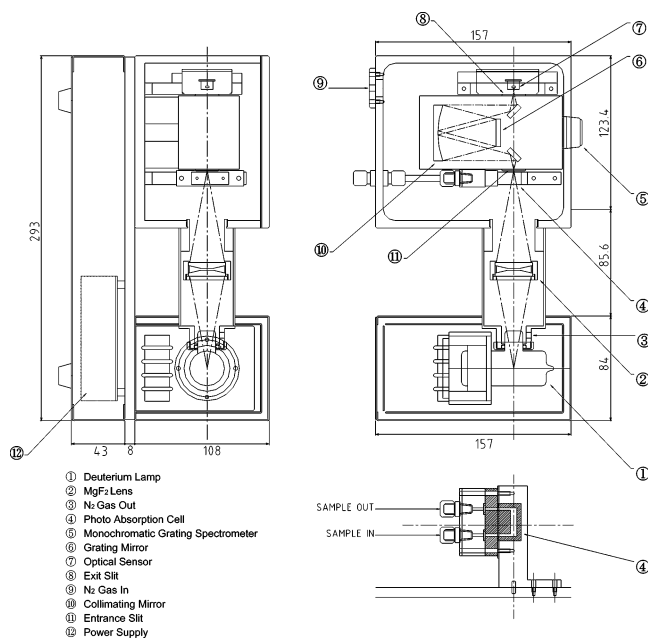

Figure 1. Schematic diagram of the developed FUV spectrometer.

described.^{21–23} So far, a UV spectroscopic method for the direct determination of PAA has not been reported probably because its UV absorption maximum is located at a very short wavelength (below 180 nm) and the extinction coefficients obtained with an ordinary UV–visible spectrometer are very low. Although recently an applicable method based on attenuated total reflectance (ATR) mid-infrared spectroscopy in combination with diamond-like carbon protected waveguides was proposed for the direct and continuous analysis of oxidizing agents in aqueous solutions,²⁵ the method is suitable only for highly concentrated oxidizing processes such as a paper bleaching process. The concentration range proposed was up to 10%, and the detection limit was $\sim 0.2\%$. This was because the evanescently guided radiation was absorbed only in the evanescent field along the ATR probe surface.

In this paper we demonstrate the usefulness of far-ultraviolet (FUV) absorption spectroscopy for the direct determination of three species, PAA, H_2O_2 , and AA, in their coexistent solutions. This method allows one to perform the very rapid, highly selective, highly sensitive, and continuous simultaneous determination of the three species without any reagents and complicated procedures. We recently reported the potential of FUV absorption spectroscopy in the determination of ionic solutes in aqueous solutions.³¹ It was found in our study that the eight kinds of natural mineral waters can be discriminated straightforwardly from the spectral patterns in the 190–250-nm region, and the FUV absorption spectroscopy also achieves the highly sensitive determination of HCl in aqueous solutions.³¹ Since the method proposed in the present study uses the 180–220-nm region (vacuum ultraviolet region), we have developed a very simple and sensitive FUV spectrometer with N_2 gas purge. A thin diamond film sensor enables us to develop the small and stable on-line spectrometer. Our method is quite useful for the real-time analysis of PAA disinfectant solutions in the sterilization process.

Development of a New FUV Spectrometer. Figure 1 illustrates a schematic of the FUV spectrometer developed by us.

- (9) Boullion, G.; Lick, C.; Schank, K. In *The Chemistry of Functional Groups, Peroxides*; Patai, S., Ed.; John Wiley & Sons: London, 1983; pp 287–298.
- (10) D'Ans, J.; Frey, W. *Chem. Ber.* **1912**, *45*, 1845.
- (11) Greenspan, F. P.; Mckellar, D. G. *Anal. Chem.* **1948**, *20*, 1061–1063.
- (12) Tay, B. T.; Tat, K. P.; Gunasingham, H. *Analyst* **1988**, *113*(4), 617–620.
- (13) Westbroek, P.; Van Haute, P.; Temmerman, E. *Fresenius' J. Anal. Chem.* **1996**, *354* (4), 405–409.
- (14) Awad, M. I.; Harnooode, C.; Tokuda, K.; Ohsaka, T. *Anal. Chem.* **2001**, *73*, 1839–1843.
- (15) Awad, M. I.; Oritani, T.; Ohsaka, T. *Anal. Chem.* **2003**, *75*, 2688–2693.
- (16) Cairns, G. T.; Ruiz, D. R.; Selby, K.; Waddington, D. J. *J. Chromatogr.* **1975**, *103*, 381–384.
- (17) Kirk, O.; Damhus, T.; Christensen, M. W. *J. Chromatogr.* **1992**, *606*, 49–53.
- (18) Pinkernell, U.; Karst, U.; Cammann, K. *Anal. Chem.* **1994**, *66*, 2599–2602.
- (19) Pinkernell, U.; Effkemann, S.; Karst, U. *Anal. Chem.* **1997**, *69*, 3623–3627.
- (20) Effkemann, S.; Pinkernell, U.; Neumuller, R.; Schwan, F.; Engelhardt, H.; Karst, U. *Anal. Chem.* **1998**, *70*, 3857–3862.
- (21) Pinkernell, U.; Lüke, H.-J.; Karst, U. *Analyst* **1997**, *122*, 567–571.
- (22) Davies, D. M.; Deary, M. E. *Analyst* **1998**, *133*, 1477–1479.
- (23) Minning, S.; Weiss, A.; Bornscheuer, U. T.; Schmid, R. D. *Anal. Chim. Acta* **1999**, *378*, 293–298.
- (24) Voraberger, H.; Ribitsch, V.; Janotta, M.; Mizaikoff, B. *Appl. Spectrosc.* **2003**, *57*, 574–579.
- (25) Janotta, M.; Vogt, F.; Voraberger, H.-S.; Waldhauser, W.; Lackner, J. M.; Stotter, C.; Beuti, M.; Mizaikoff, B. *Anal. Chem.* **2004**, *76*, 384–391.
- (26) Siesler, H. W.; Ozaki, Y.; Kawata, S.; Heise, H. M., Eds. *Near-Infrared Spectroscopy, Principles, Instruments, Applications*; Wiley-VCH: Weinheim, 2002.
- (27) Osborn, B. G.; Fearn, T.; Hindel, P. H. *Practical Near Infrared Spectroscopy with Applications in Food and Beverage Analysis*; Longman Scientific & Technical: Essex, 1993.
- (28) Burns, D. A.; Ciurczak, E. W., Eds. *Handbook of Near-Infrared Analysis*; Marcel Dekker: New York, 2001.
- (29) Williams, P.; Norris, K., Eds.; *Near-Infrared Technology in the Agriculture and Food Industries*, 3rd ed.; American Association of Cereal Chemists: St. Paul, MN, 2001.
- (30) Ozaki, Y.; Amari, T. In *Spectroscopy in Process Analysis*; Chalmers, J. M. Ed.; Sheffield Academic Press: Sheffield, 2000; p 53.

(31) Higashi, N.; Ozaki, Y. *Appl. Spectrosc.* **2004**, *58*, 910–916.

Note that its size is small, being 30 cm × 16 cm × 16 cm, including a UV light source, a grating mirror, a photoabsorption cell, and an optical sensor. FUV light from a deuterium lamp is dispersed with the grating mirror after entering the photoabsorption cell. The optical pass length of the cell used is 0.5 mm because of the large absorbance of aqueous solutions in the FUV region. The penetration depth of the UV radiation in an aqueous solution within the cell is ~45% at the measuring wavelength of 182 nm. As the UV light source we use a deuterium lamp that has the transparent window made of MgF₂ in the spectral region 180–220 nm. To change detectable wavelength monochromatically the grating mirror is set on a turning stage. The grooving pitch of the grating mirror is 2400/mm, and the blazed wavelength is 250 nm. The optical sensor detects the dispersed UV light and changes it into the electrical intensity signal. The response time to measure one spectrum in the 180–220-nm region is ~30 s.

For the determination of PAA in disinfectant solutions we do not need very high resolution of wavelength because the absorption bands of PAA, H₂O₂, and AA in the UV region are broad and we use the shoulders of their bands in the 180–220-nm region. Then, we can pay attention to detecting enough brightness in preference to the resolution of detectable wavelength. In this analysis we use our spectrometer with a 0.6-mm slit that enables us to measure the spectra with a bandwidth of ~5 nm. For the sake of the bright UV radiation we can use a thin diamond film sensor^{32–34} as an optical sensor of the FUV spectrometer. A diamond film has optical sensitivity in the region from 150 to 220 nm and operates with an easy electric power supply circuit. In addition it is very small in size: 3 cm × 3 cm × 1 cm including an electric circuit. These days, it is often used to monitor the optical intensity of an excimer laser. However, little attention has yet been paid to using the diamond film as an optical sensor for a FUV spectrometer because the optical sensitivity of the sensor is not very high. In general, a photomultiplier tube, which needs very high voltage operation and vast setting space and has large signal drifts with the changes in temperature, is used as an optical sensor for commercial FUV spectrometers that achieve the resolution of detectable wavelength lower than 0.5 nm. Thus, the commercial FUV spectrometers are usually very big and need a calibration frequently. Furthermore, it needs a large vacuum pump or a great deal of purge air such as nitrogen or argon gas to remove oxygen from its large optical measuring area. It causes the fatal weak point for on-line use of these FUV spectrometers in process analyses. On the other hand, our FUV spectrometer, which employs the diamond film as an optical sensor, is very small and stable and suitable for the on-line use. The flow rate of N₂ gas blown into the measuring area is only 0.1 L/min.

EXPERIMENTAL SECTION

Preparation and Evaluation of Test Solutions. A commercial condensed PAA solution (AKTIVE90) was purchased from Ecolab Inc. The concentrations of PAA, H₂O₂, and AA in AKTIVE90 were 8.6, 23, and 22 wt %, respectively. Then, AKTIV90

Table 1. Concentrations of PAA, H₂O₂, and AA in the 19 Sample Solutions Used To Develop Calibration Models

sample no.	concentrations (wt %)		
	PAA	H ₂ O ₂	AA
1	0.020	0.105	0.095
2	0.022	0.149	0.067
3	0.019	0.128	0.050
4	0.019	0.059	0.052
5	0.019	0.104	0.098
6	0.019	0.082	0.073
7	0.019	0.082	0.067
8	0.017	0.152	0.137
9	0.018	0.128	0.115
10	0.016	0.130	0.119
11	0.011	0.134	0.149
12	0.011	0.107	0.101
13	0.012	0.087	0.034
14	0.013	0.040	0.083
15	0.013	0.039	0.033
16	0.005	0.021	0.131
17	0.003	0.021	0.017
18	0.005	0.111	0.017
19	0.004	0.068	0.063

was diluted with pure water, an aqueous solution of H₂O₂, or an aqueous solution of acetic acid. Distilled and deionized water was used for the dilution throughout the experiments. We prepared 19 sample solutions to build calibration models for predicting the concentration of each species. First, we obtained them with the concentration ranges from 0.15 to 0.40 wt % for PAA, from 0.20 to 1.50 wt % for H₂O₂, and from 0.20 to 1.50 wt % for AA and then titrated the concentration of each species by the usual titration methods. Next, these 19 samples were diluted with a 10 times volume of pure water, and FUV spectra of the diluted solutions were measured with the newly developed FUV spectrometer.

Titration of the 19 Sample Solutions. Table 1 summarizes the concentrations of the test solutions obtained by using the titration methods. For the determination of PAA and H₂O₂, we employed a two-step titration method, which was developed by modifying the method originally proposed by D'Ans and Frey.¹⁰ On the other hand, common neutralized titration with sodium hydroxide was employed for the determination of AA. For each sample, titration was carried out three times and the average value was calculated.

Measurements of the FUV Spectra of PAA Solutions. While the FUV measurements were performed with the FUV spectrometer, a peristaltic pump assured the constant flow rate of the test solutions through the flow cell at 5 mL/min. Prior to the FUV measurements of the sample solutions, pure water was pumped into the cell and a background spectrum was recorded. The temperature of water and sample solutions was kept at 25 °C. A FUV spectrum of each sample solution was measured after the solution had been flowing through the cell for 1 min to ensure the replace of new sample.

Data Analysis. For the data analysis of the FUV spectra of three-component systems, we used multiple linear regression. We chose seven wavelengths (182, 185, 187.5, 190, 200, 205, 210 nm) to build calibration models for predicting the concentrations of three components.

(32) Lansley, S. P.; Gaudin, O.; Whitfield, D. M.; McKeag, R. D.; Rizvi, N.; Jackman, R. B. *Diamond Relat. Mater.* **2000**, *9*, 195–200.

(33) McKeag, R. D.; Chan, S. S. M.; Jackman, R. B. *Appl. Phys. Lett.* **1995**, *67*, 2117–2119.

(34) Landstrass, M. I.; Plano, M. A.; Moreno, M. A.; McWilliams, S.; Pan, L. S.; Kania, D. R.; Han, S. *Diamond Relat. Mater.* **1993**, *2*, 1033–1037.

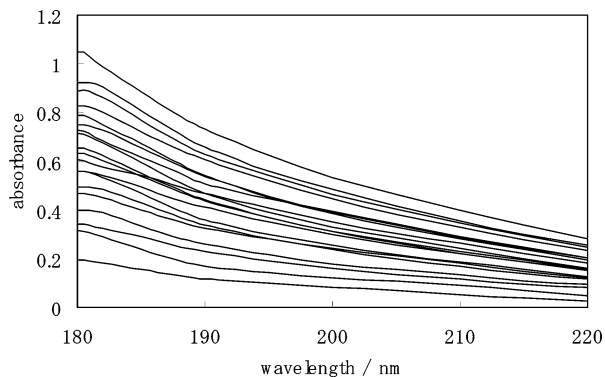

Figure 2. FUV absorption spectra of the 19 kinds of sample solutions that contain PAA, H₂O₂, and AA with different concentrations. These spectra were used to develop calibration models.

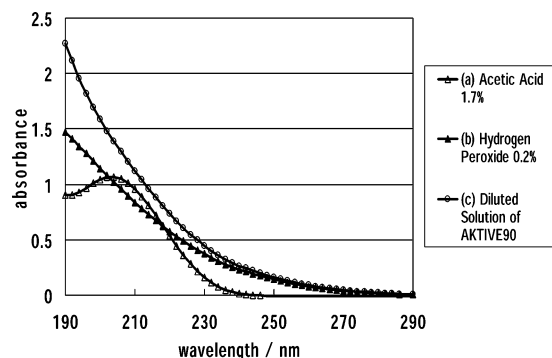

Figure 3. FUV absorption spectra of (a) an aqueous solution of AA with the concentration of 1.7 wt %, (b) an aqueous solution of H₂O₂ with the concentration of 0.2 wt %, and (c) a diluted PAA disinfectant solution (AKTIVE90) with the concentrations of 0.86, 0.23, and 0.22 wt % for PAA, H₂O₂, and AA, respectively.

RESULTS AND DISCUSSION

Analyses of FUV Spectra. Figure 2 shows FUV absorption spectra in the 180–220-nm region of the 19 sample solutions shown in Table 1 measured by using the new FUV spectrometer. It is noted that all the spectra are distinctly different from each other. PAA and AA are characterized by their absorption bands in the FUV region;^{35,36} the absorption maximum of AA appears around 205 nm and that of PAA is located at a shorter wavelength below 180 nm.³⁶ On the other hand, an aqueous solution of H₂O₂ shows a broader absorption spectrum below 280 nm. Although the absorption maximums of PAA and H₂O₂ cannot be observed in the 180–220-nm region, their shoulders show different inclinations.

To discuss these differences in the spectra in more detail, we obtained several spectra of aqueous solutions that contain PAA and/or H₂O₂ and/or AA. Figure 3 depicts FUV absorption spectra of (a) an aqueous solution of AA with the concentration of 1.7 wt %, (b) an aqueous solution of H₂O₂ with the concentration of 0.2 wt %, and (c) a PAA disinfectant solution with the concentrations of 0.86, 0.23, and 0.22 wt % of PAA, H₂O₂, and AA, respectively. The spectra in Figure 3 were obtained by using a commercial spectrometer (Shimadzu UV–visible spectrophotometer: UV-2550) and a cuvette cell with a path length of 10 mm. Figure 4

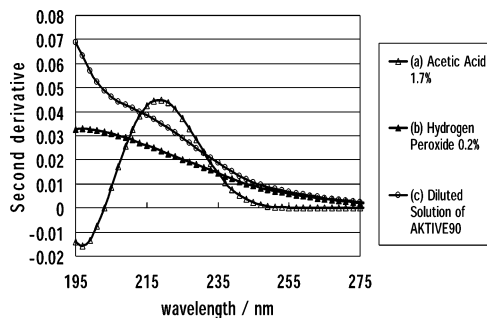

Figure 4. Second-derivative spectra of the FUV absorption spectra shown in Figure 3.

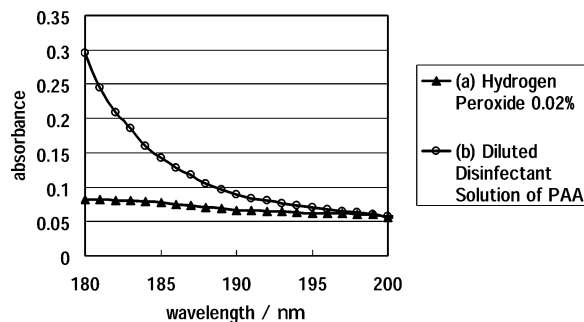

Figure 5. FUV absorption spectra of (a) an aqueous solution of H₂O₂ with the concentration of 0.02 wt % and (b) a diluted disinfectant solution of PAA with the concentrations of 0.01, 0.02, and 0.05 wt % for PAA, H₂O₂, and AA, respectively.

presents their second-derivative spectra. It can be seen from Figures 3 and 4 that one can use these spectra for the determination of each solute in the coexistence of their species. So far, little attention has been given to the study that tries to use these absorption spectra for the determination of PAA in a disinfectant solution because a UV absorption band due to PAA in the disinfectant solution, which is measured by using an ordinary UV–visible spectrometer, has very small extinction coefficient in the concentration range lower than 0.2 wt %, and the UV band is usually interfered with by the coexistence of a great deal of H₂O₂ in the disinfectant solution. The typical concentration ranges of PAA and H₂O₂ in practical disinfectant solutions are between 0.1 and 0.2 wt % and between 0.5 and 2.0 wt %, respectively. However, we have found that in the diluted disinfectant solutions a characteristic absorption band due to PAA appears below 190 nm because the intensity of the absorption due to H₂O₂ decreases with the dilution of the disinfectant solutions, while the intensity of the absorption due to PAA sufficiently remains below 190 nm.

Figure 5 shows absorption spectra of (a) an aqueous solution of H₂O₂ with the concentration of 0.02 wt % and (b) a diluted disinfectant solution containing 0.01 wt % PAA, 0.02 wt % H₂O₂, and 0.05 wt % AA. They were obtained by using our original spectrometer. This figure clearly reveals that in the disinfectant solution PAA shows significant absorption below 190 nm in comparison with that of H₂O₂.

We built calibration models using the 19 kinds of spectral data shown in Figure 2 and Table 1. Panels a–c of Figure 6 show the calibration models for predicting the concentrations of PAA, H₂O₂, and AA, respectively. As can be seen from Figure 6, all the measured concentrations of the three species are in very good agreement between the spectral analysis and the titration method.

(35) Orlando, J. J.; Tyndall, G. S. *J. Photochem. Photobiol.* **2003**, *A157*, 161–166.

(36) Giguere, P. A.; Olmos, A. W. *Can. J. Chem.* **1956**, *34*, 689–691.

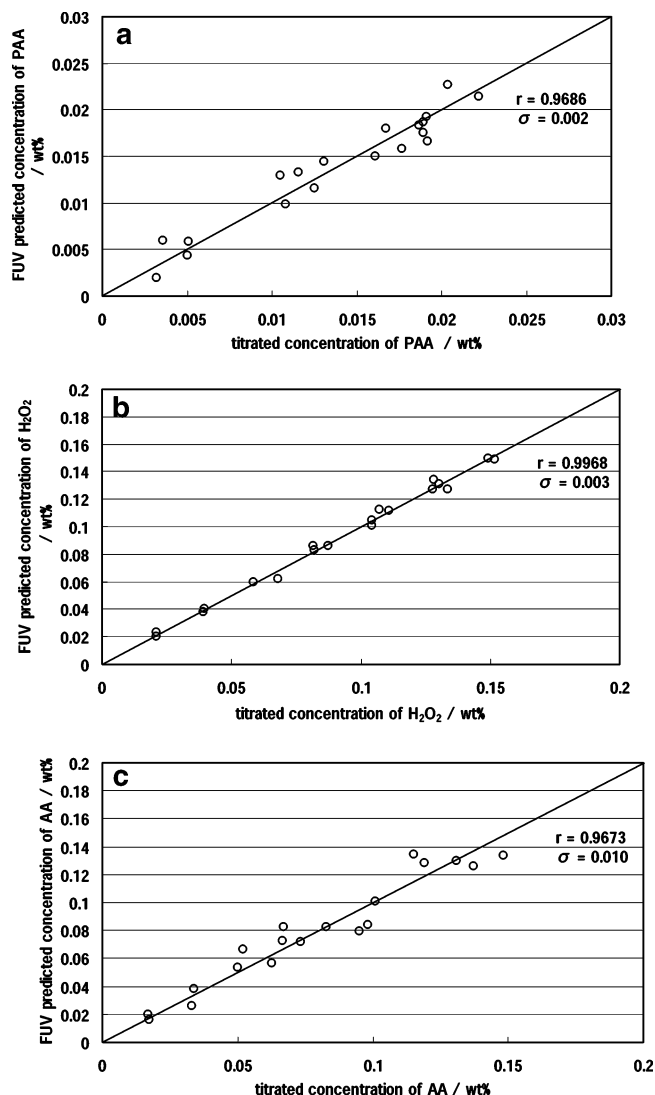

Figure 6. Calibration models for predicting the concentrations of (a) PAA, (b) H_2O_2 , and (c) AA in the concentration range from 0 to 0.02, 0 to 0.15, and 0 to 0.15 wt % for PAA, H_2O_2 , and AA, respectively.

The correlation coefficient and standard error of the prediction for PAA, H_2O_2 , and AA were 0.969 and 0.002, 0.997 and 0.003, and 0.967 and 0.01 wt %, respectively. This result shows the online monitoring for the concentration of PAA in the disinfectant solution is possible with an accuracy of 0.002 wt %.

Possible Spectral Interference of Contaminations in the UV Range below 200 nm. It is important to note that the spectral interference of many organic and inorganic compounds in the spectral region below 200 nm may become one of the anxieties of this spectral method. However, since the disinfectant solutions in the practical processes such as the sterilization of pet bottle beverages should consist of pure water, PAA, H_2O_2 , and AA and be kept very clean, such impurities may be controlled. Of course, some contaminations from these bottles may remain in the disinfectant solutions. However, the amounts of the contamination seem to be neglected for measuring the absorbance of PAA because it is quite likely that an excess of the contaminations, which causes significant changes in a FUV absorption spectrum of a disinfectant solution measured by use of a cell with the path length of only 0.5 mm, does not clean but contaminates a bottle.

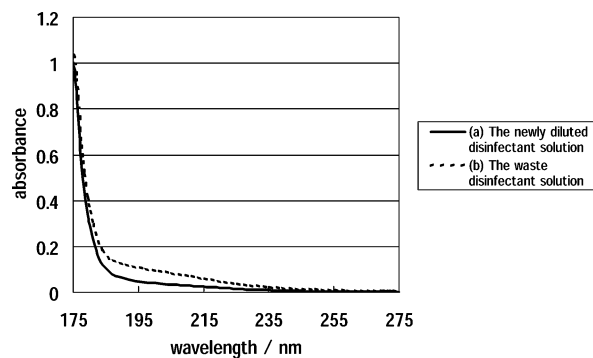

Figure 7. FUV absorption spectra of (a) the newly diluted disinfectant solution and (b) the waste disinfectant solution.

Although it is known that dissolved oxygen also shows an absorption band below 200 nm, the concentration of dissolved oxygen in aqueous solutions is almost constant: just ~ 8 ppm under the pressure of the atmosphere at room temperature. Therefore, with the narrow limits of the process analysis of disinfectant solutions the spectral interference by the changes in the concentration of dissolved oxygen seems to be small enough compared with the absorbance due to PAA or H_2O_2 in the spectral region around 180 nm. To make these assumptions clear, we undertook the following experiment.

First, we obtained the newly diluted disinfectant solution that might be used in a practical sterilization process. We also obtained the waste disinfectant solution that had been used in an actual process. Next, we measured FUV absorption spectra of both actual disinfectant solutions, and then carried out a determination of PAA by using our original spectrometer. Figure 7 shows absorption spectra in the region of 175–300 nm of (a) the newly diluted disinfectant solution and (b) the waste disinfectant solution. These spectra in Figure 7 were measured by using a commercial available vacuum-ultraviolet spectrometer (Hitachi U-7000) and a MgF_2 cell with a path length of 0.1 mm, and pure water was used for reference. The resolution of the spectrum was set to be 0.1 nm not to miss a very sharp band. As is evident in Figure 7b, there is no peak assignable to contaminations in this spectral region. One distinct difference between the spectra a and b is an increase of a broad absorption due to H_2O_2 below 250 nm in spectrum b. Since a drip of condensed disinfectant solution is added several times in the lifetime of actual disinfectant solution to cover the loss of PAA in its circulation use, the concentration of H_2O_2 always increases with the progress of the process, while the concentration of PAA is kept almost constant. Table 2 summarizes the results of the determination of PAA, H_2O_2 , and AA by using the titration method and the proposed spectral method. As the results show, the present method is quite useful for the determination of three species in the practical disinfectant solutions.

Sample Decomposition by UV Radiation. It must be necessary to keep in mind that UV radiation causes the decomposition of PAA and H_2O_2 in their solutions.^{37,38} To estimate the influence of UV radiation on the spectroscopic analysis, we undertook the following experiment. First, the cuvette cell was

(37) Caretti, C.; Lubello, C. *Water Res.* **2003**, *37*, 2365–2371.

(38) Rajala-Mustonen, R. L.; Toivola, P. S.; Heinonen-Tanski, H. *Water Sci. Technol.* **1997**, *35*, 237–241.

Table 2. Results of the Determination of PAA, H₂O₂, and AA in Actual Disinfectant Solutions by Using the Titration Method and the Proposed Spectral Method

methods	concentrations (wt %)					
	newly diluted disinfectant solution			waste disinfectant solution		
	PAA	H ₂ O ₂	AA	PAA	H ₂ O ₂	AA
titration	0.101	0.502	0.673	0.048	1.387	1.761
FUV measurement	0.098	0.528	0.605	0.054	1.355	1.683

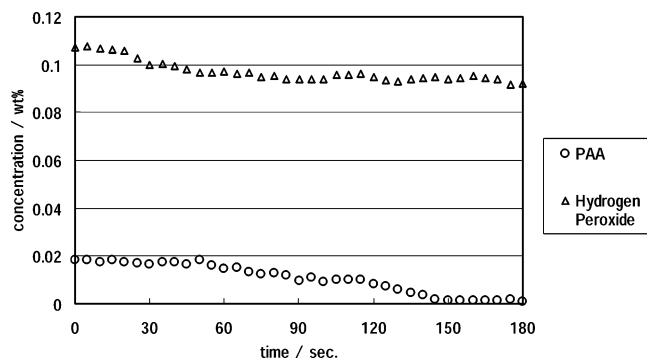

Figure 8. Decomposition curves of PAA and H₂O₂ in the diluted disinfectant solution exposed to UV irradiation. The curves were calculated as follows. First, the measuring wavelength was fixed at 182 nm, and the absorbance at 182 nm was recorded with an interval of 5 s for 3 min. Then, the absorbencies at other 6 wavelengths were measured in due order after the sample was replaced in the cell.

filled with pure water to calibrate zero adjustment. Next, a PAA disinfectant solution with the concentrations of 0.02 wt % for PAA, 0.11 wt % for H₂O₂, and 0.06 wt % for AA was placed in the cell

and left for 3 min under the FUV irradiation with the power of a deuterium lamp of 50 W. The concentrations for PAA and H₂O₂ were measured with an interval of 5 s, and the results are depicted in Figure 8. This figure shows that the decomposition starts in 30 s. Consequently, the FUV spectroscopic measurements should be carried out under the flow sample conditions; the instant UV radiation at a flow rate over 5 mL/min is almost negligible for the sample decomposition because the residence time in the measuring cell is less than 15 s.

CONCLUSION

The present study has demonstrated the usefulness of FUV spectroscopy in the simultaneous quantitative analysis of PAA, H₂O₂, and AA in a disinfectant solution of PAA. This method is very simple and rapid in the spectral measurements and analyses. It does not request any reagents for the analysis and leave any impurities in the analyzed solutions. For the present purpose we have developed a new FUV spectrometer with simple N₂ gas purge. By using this spectrometer we could achieve the detection limit of 0.002 wt % for PAA, 0.003 wt % for H₂O₂, and 0.01 wt % for AA. The analysis needs a dilution of H₂O₂ with water to a concentration range lower than 0.2 wt % in the analyzed solutions, but an automatic dilution system may achieve the continuous direct determination of PAA in a disinfectant solution on the actual CIP process. We are currently involved in the development of a highly sensitive FUV spectroscopic monitoring system with an automatic dilution system, by which we expect to perform real-time monitoring of a flowing disinfectant solution on-line.

Received for review August 31, 2004. Accepted January 12, 2005.

AC0487045